

Electronic Console

www.edibon.com

- Products
- Products range
- Units
- 9 - Thermodynamics & Thermotechnics

PROCESS DIAGRAM AND ELEMENTS ALLOCATION

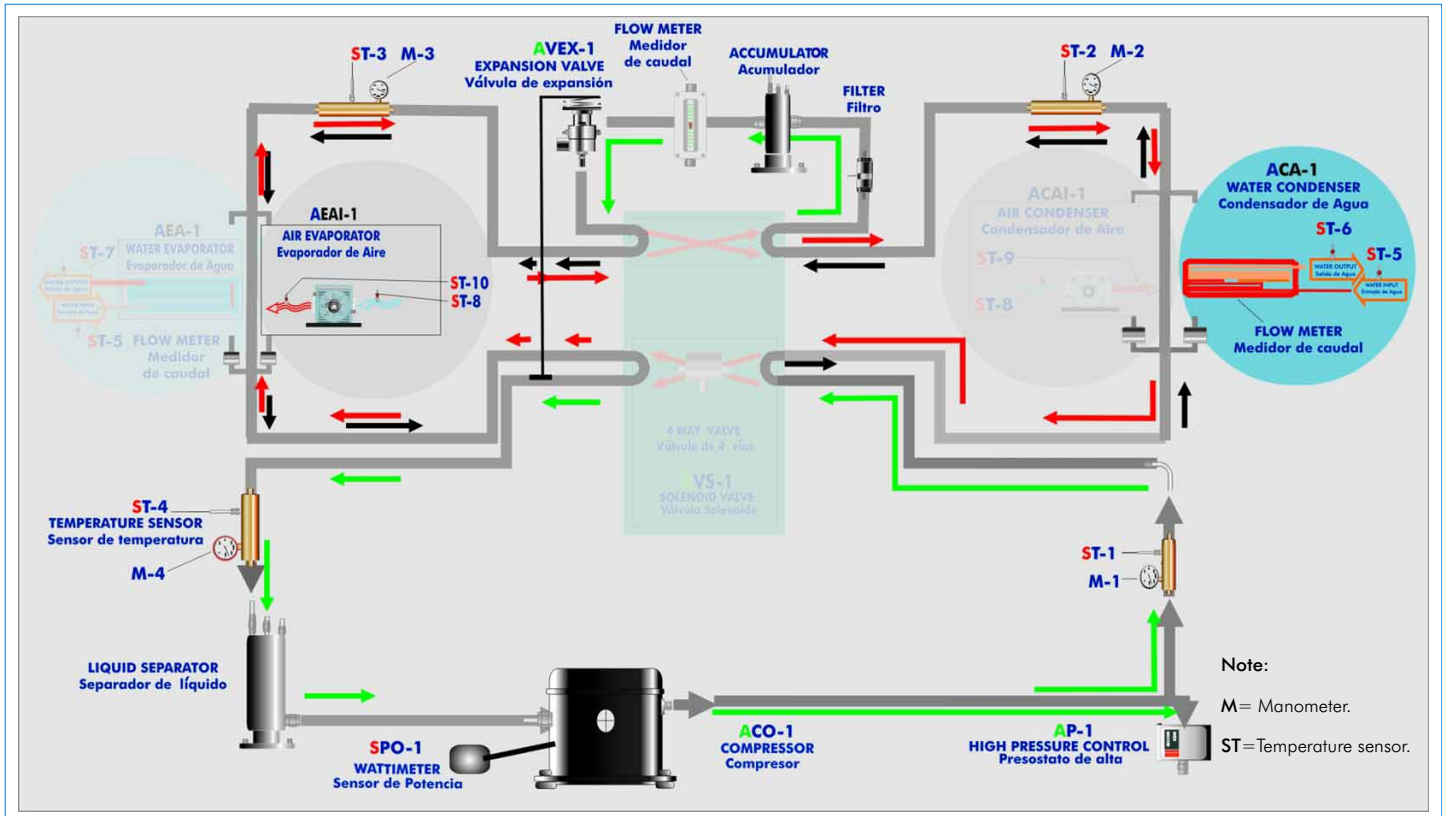

SPECIFICATIONS

Bench-top unit.

Anodized aluminium structure and panels in painted steel.

Main metallic elements in stainless steel.

Diagram in the front panel with similar distribution to the elements in the real unit.

Cooling compressor.

Water condenser.

High pressure control.

Coolant accumulation tank.

Cooling filter.

Expansion valve.

Air evaporator.

Tank of division of the cooling liquid.

4 Manometers.

8 Temperature sensors (4 sensors measure the cooling temperature, 2 sensors measure the water temperature, 2 sensors measure the air temperature):

Temperature sensor, J type (compressor outlet).

Temperature sensor, J type (condenser outlet).

Temperature sensor, J type (evaporator inlet).

Temperature sensor, J type (compressor inlet).

Temperature sensor, J type (water inlet).

Temperature sensor, J type (condenser outlet/water).

Temperature sensor, J type (evaporator outlet/air).

Temperature sensor, J type (room air).

Flow meters.

Wattmeter.

Enthalpy diagram of the refrigerant R134a.

Electronic Console:

Metallic box.

Temperature sensors connections.

Selector for temperature sensors.

Digital display for temperature sensors.

High pressure control connection.

Fan speed regulator.

Wattmeter display.

Compressor ON/OFF switch.

Electronic Console ON/OFF switch.

Cables and Accessories, for normal operation.

Manuals: This unit is supplied **with the following manuals:** Required Services, Assembly and Installation, Starting-up, Safety, Maintenance & Practices Manuals.

EXERCISES AND PRACTICAL POSSIBILITIES

Some Practical Possibilities of the Unit:

- 1.- Determination of the inlet power, heat produced and performance coefficient. Air as heat source.
- 2.- Preparation of performance curves of the heat pump with different inlet and outlet temperatures. Air as heat source.
- 3.- Lay out of the steam compression cycle in a diagram P-H and comparison with the ideal cycle. Air as heat source.
- 4.- Preparation of the performance curves of the heat pump based on the properties of the refrigerant and at different condensation and evaporation temperatures. Air as heat source.
- 5.- Energy balances.

REQUIRED SERVICES

Electrical supply: 220V, 1-phase + neutral + ground, 50 Hz.; or 110V, 1-phase + neutral + ground, 60Hz.; and 1 CV max.

Water supply and drainage.

DIMENSIONS & WEIGHTS

THBLAB:

Unit: -Dimensions: 900 x 600 x 500 mm. approx.
-Weight: 75 Kg. approx.

Electronic Console: -Dimensions: 490 x 330 x 310 mm. approx.
-Weight: 15 Kg. approx.

RECOMMENDED ACCESSORIES

For refilling R134a refrigerant and maintenance, we recommend:

- T/KIT1. Maintenance Kit, containing: vacuum pump, hoses and manometers.
- T/KIT2. Maintenance Kit, containing: leakage detector.
- R134a refrigerant (to be acquired by the customer locally).

AVAILABLE VERSIONS

Offered in this catalogue:

- **THBLAB. Heat Pump Unit (one condenser (water) and one evaporator (air)).**

Offered in other catalogue:

- **THBLAC. Computer Controlled Heat Pump Unit (one condenser (water) and one evaporator (air)).**

OTHER AVAILABLE HEAT PUMP UNITS

- **THIBAR22C. Computer Controlled Heat Pump+ Air Conditioning + Refrigeration Unit with Cycle Inversion Valve.**
- **THIBAR22B. Heat Pump+ Air Conditioning + Refrigeration Unit with Cycle Inversion Valve.**
- **THB22C. Computer Controlled Heat Pump Unit (two condensers (water and air) and two evaporators (water and air)).**
- **THB22B. Heat Pump Unit (two condensers (water and air) and two evaporators (water and air)).**
- **THB2LC. Computer Controlled Heat Pump Unit (two condensers (water and air)and one evaporator (water)).**
- **THB2LB. Heat Pump Unit (two condensers (water and air)and one evaporator (water)).**
- **THBL2C. Computer Controlled Heat Pump Unit (one condenser (water) and two evaporators (water and air)).**
- **THBL2B. Heat Pump Unit (one condenser (water) and two evaporators (water and air)).**
- **THBA2C. Computer Controlled Heat Pump Unit (one condenser (air) and two evaporators (water and air)).**
- **THBA2B. Heat Pump Unit (one condenser (air) and two evaporators (water and air)).**
- **THBALC. Computer Controlled Heat Pump Unit (one condenser (air)and one evaporator (water)).**
- **THBALB. Heat Pump Unit (one condenser (air)and one evaporator (water)).**
- **THB2AC. Computer Controlled Heat Pump Unit (two condensers (water and air) and one evaporator (air)).**
- **THB2AB. Heat Pump Unit (two condensers (water and air) and one evaporator (air)).**
- **THBLLC. Computer Controlled Heat Pump Unit (one condenser (water)and one evaporator (water)).**
- **THBLLB. Heat Pump Unit (one condenser (water)and one evaporator (water)).**
- **THBAAC. Computer Controlled Heat Pump Unit (one condenser (air)and one evaporator (air)).**
- **THBAAB. Heat Pump Unit (one condenser (air)and one evaporator (air)).**

* Specifications subject to change without previous notice, due to the convenience of improvements of the product.



C/ Del Agua, 14. Polígono Industrial San José de Valderas.
28918 LEGANÉS (Madrid). SPAIN.
Phone: 34-91-6199363 FAX: 34-91-6198647
E-mail: edibon@edibon.com WEB site: www.edibon.com

Issue: ED01/10
Date: September/2010

REPRESENTATIVE: