

① Unit: THARL2C. Refrigeration and Air Conditioning Unit (one condenser (water) and two evaporators (water and air))

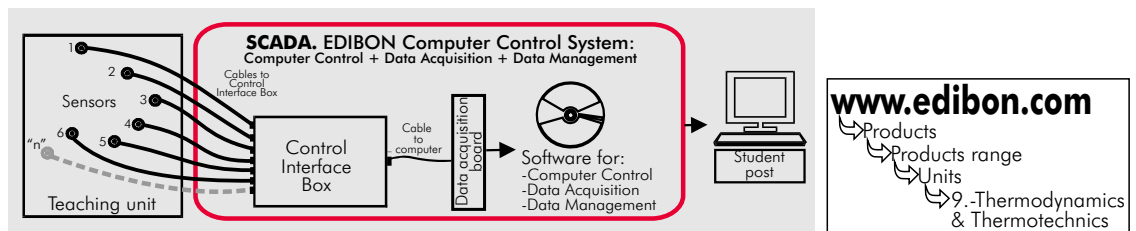

PROCESS DIAGRAM AND ELEMENTS ALLOCATION

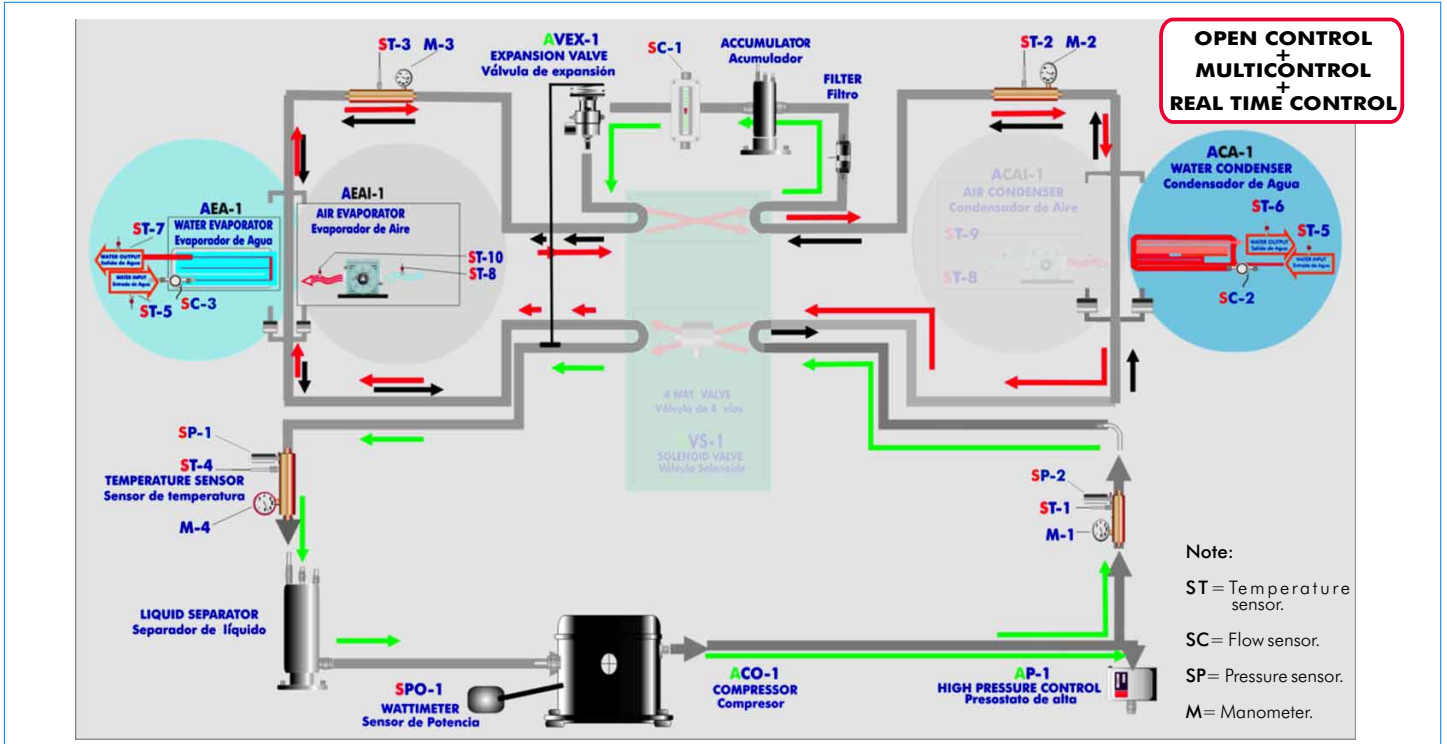

Items supplied as standard

① THARL2C. Unit:

- Bench-top unit.
- Anodized aluminium structure and panels in painted steel (epoxy paint).
- Main metallic elements in stainless steel.
- Diagram in the front panel with similar distribution to the elements in the real unit.
- Cooling compressor, computer controlled.
- Water condenser.
- Air evaporator, computer controlled.
- Water evaporator.
- High pressure control.
- Coolant accumulation tank.
- Cooling filter.
- Expansion valve.
- Tank of division of the cooling liquid.
- 4 Manometers.
- 9 Temperature sensors:
 - Temperature sensor, J type (compressor outlet).
 - Temperature sensor, J type (condenser outlet).
 - Temperature sensor, J type (evaporator inlet).
 - Temperature sensor, J type (compressor inlet).
 - Temperature sensor, J type (water inlet).
 - Temperature sensor, J type (condenser outlet/water).
 - Temperature sensor, J type (water evaporator outlet/water).
 - Temperature sensor, J type (air evaporator outlet/air).
 - Temperature sensor, J type (room air).



THARL2C. Unit

- 3 Flow sensors:
 - Cooling flow sensor.
 - Water flow sensor (water condenser). Water flow sensor (water evaporator).
- 2 Pressure sensors:
 - Cooling pressure sensor (compressor outlet). Cooling pressure sensor (compressor inlet).
- Wattmeter.

Enthalpy diagram of the refrigerant R134a.

② THARL2C/CIB. Control Interface Box:

Control interface box with process diagram in the front panel and with the same distribution that the different elements located in the unit, for an easy understanding by the student.

All sensors, with their respective signals, are properly manipulated from -10V. to +10V computer output. Sensors connectors in the interface have different pines numbers (from 2 to 16), to avoid connection errors. Single cable between the control interface box and computer.

The unit control elements are permanently computer controlled, without necessity of changes or connections during the whole process test procedure.

Simultaneously visualization in the computer of all parameters involved in the process.

Calibration of all sensors involved in the process.

Real time curves representation about system responses. Storage of all the process data and results in a file. Graphic representation, in real time, of all the process/system responses.

All the actuators' values can be changed at any time from the keyboard allowing the analysis about curves and responses of the whole process.

All the actuators and sensors values and their responses are placed in only one computer screen.

Shield and filtered signals to avoid external interferences.

Real time computer control with flexibility of modifications from the computer keyboard of the parameters, at any moment during the process. Real time computer control for pumps, compressors, resistances, control valves, etc.

Open control allowing modifications, at any time and in a real time, of parameters involved in the process simultaneously.

Three safety levels, one mechanical in the unit, other electronic in control interface and the third one in the control software.

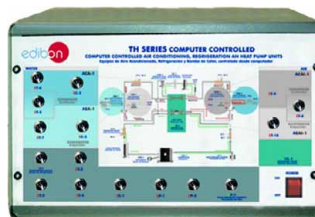

THARL2C/CIB

③ DAB. Data Acquisition Board:

PCI Data acquisition board (National Instruments) to be placed in a computer slot. Bus PCI.

Analog input: Channels= 16 single-ended or 8 differential. Resolution= 16 bits, 1 in 65536. Sampling rate up to: 250 KS/s (Kilo samples per second). Input range (V)=±10V. Data transfers=DMA, interrupts, programmed I/O. Number of DMA channels=6.

Analog output: Channels=2. Resolution= 16 bits, 1 in 65536. Maximum output rate up to: 833 KS/s. Output range(V)=±10V. Data transfers=DMA, interrupts, programmed I/O.

Digital Input/Output: Channels=24 inputs/outputs. DO or DI Sample Clock frequency: 0 to 1 MHz.

Timing: Counter/timers=2. Resolution: Counter/timers: 32 bits.



DAB

④ THARL2C/CCSOF. Computer Control+Data Acquisition+Data Management Software:

Compatible with actual Windows operating systems. Graphic and intuitive simulation of the process in screen. Compatible with the industry standards.

Registration and visualization of all process variables in an automatic and simultaneously way.

Flexible, open and multicontrol software, developed with actual windows graphic systems, acting simultaneously on all process parameters.

Management, processing, comparison and storage of data.

Sampling velocity up to 250,000 data per second guaranteed.

Calibration system for the sensors involved in the process.

It allows the registration of the alarms state and the graphic representation in real time.

Comparative analysis of the obtained data, after the process and modification of the conditions during the process.

Open software, allowing to the teacher to modify texts, instructions. Teacher's and student's passwords to facilitate the teacher's control on the student, and allowing the access at different work levels.

This unit allows that the 30 students of the classroom can visualize simultaneously all results and manipulation of the unit, during the process, by using a projector.

⑤ Cables and Accessories, for normal operation.

⑥ Manuals: This unit is supplied with 8 manuals: Required Services, Assembly and Installation, Interface and Control Software, Starting-up, Safety, Maintenance, Calibration & Practices Manuals.



THARL2C/CCSOF

*** References 1 to 6: THARL2C + THARL2C/CIB + DAB + THARL2C/CCSOF + Cables and Accessories + Manuals are included in the minimum supply, enabling a normal operation.**

Continue...

Complementary items to the standard supply

PLC. Industrial Control using PLC (7 and 8):

⑦ PLC-PI. PLC Module:

Circuit diagram in the front panel.

Front panel:

Digital inputs(X) and Digital outputs (Y) block:

16 Digital inputs, activated by switches and 16 LEDs for confirmation (red).

14 Digital outputs (through SCSI connector) with 14 LEDs for message (green).

Analog inputs block:

16 Analog inputs (-10V. to + 10V.)(through SCSI connector).

Analog outputs block:

4 Analog outputs (-10V. to + 10V.)(through SCSI connector).

Touch screen:

High visibility and multiple functions.

Display of a highly visible status.

Recipe function.

Bar graph function.

Flow display function.

Alarm list.

Multi language function.

True type fonts.

Back panel:

Power supply connector.

Fuse 2A.

RS-232 connector to PC.

USB 2.0 connector to PC.

Inside:

Power supply outputs: 24 Vdc, 12 Vdc, -12 Vdc, 12 Vdc variable.

Panasonic PLC:

High-speed scan of 0.32 μsec. for a basic instruction.

Program capacity of 32 Ksteps, with a sufficient comment area.

Free input AC voltage(100 to 240 V AC).

DC input: 16 (24 VDC).

Relay output: 14 (250 VA AC/2 A).

High-speed counter.

Multi-point PID control.

Digital inputs/outputs and analog inputs/outputs Panasonic modules.

Communication RS232 wire, to computer (PC).

⑧ THARL2C/PLC-SOF. PLC Control Software:

For this particular unit, always included with PLC supply.

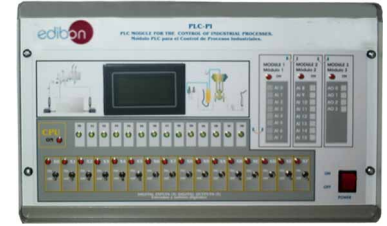

PLC-PI

Items available on request

⑨ THARL2C/CAL. Computer Aided Learning Software (Results Calculation and Analysis).

⑩ THARL2C/FSS. Faults Simulation System.

REQUIRED SERVICES

Electrical supply: 220V, 1-phase + neutral + ground, 50 Hz.; or 110V, 1-phase + neutral + ground, 60Hz.; and 1 CV max.

Water supply and drainage.

Computer (PC).

DIMENSIONS & WEIGHTS

THARL2C Unit: -Dimensions: 900 x 600 x 500 mm. approx.

-Weight: 85 Kg. approx.

Control Interface Box: -Dimensions: 490 x 330 x 310 mm. approx.

-Weight: 10 Kg. approx.

PLC Module (PLC-PI): -Dimensions: 490 x 330 x 310 mm. approx.

-Weight: 30 Kg. approx.

RECOMMENDED ACCESSORIES

For refilling R134a refrigerant and maintenance, we recommend:

- T/KIT1. Maintenance Kit, containing: vacuum pump, hoses and manometers.
- T/KIT2. Maintenance Kit, containing: leakage detector.
- R134a refrigerant (to be acquired by the customer locally).

AVAILABLE VERSIONS

Offered in this catalogue:

- **THARL2C. Computer Controlled Refrigeration and Air Conditioning Unit (one condenser (water) and two evaporators (water and air)).**

Offered in other catalogue:

- **THARL2B. Refrigeration and Air Conditioning Unit (one condenser (water) and two evaporators (water and air)).**

OTHER AVAILABLE REFRIGERATION AND AIR CONDITIONING UNITS

- **THAR22C. Computer Controlled Refrigeration and Air Conditioning Unit (two condensers (water and air) and two evaporators (water and air)).**
- **THAR22B. Refrigeration and Air Conditioning Unit (two condensers (water and air) and two evaporators (water and air)).**
- **THAR21C. Computer Controlled Refrigeration and Air Conditioning Unit (two condensers (water and air) and one evaporator (water)).**
- **THAR21B. Refrigeration and Air Conditioning Unit (two condensers (water and air) and one evaporator (water)).**
- **THARA2C. Computer Controlled Refrigeration and Air Conditioning Unit (one condenser (air) and two evaporators (water and air)).**
- **THARA2B. Refrigeration and Air Conditioning Unit (one condenser (air) and two evaporators (water and air)).**
- **THARALC. Computer Controlled Refrigeration and Air Conditioning Unit (one condenser (air) and one evaporator (water)).**
- **THARALB. Refrigeration and Air Conditioning Unit (one condenser (air) and one evaporator (water)).**
- **THARLLC. Computer Controlled Refrigeration and Air Conditioning Unit (one condenser (water) and one evaporator (water)).**
- **THARLLB. Refrigeration and Air Conditioning Unit (one condenser (water) and one evaporator (water)).**

* Specifications subject to change without previous notice, due to the convenience of improvements of the product.



C/ Del Agua, 14. Polígono Industrial San José de Valderas.
28918 LEGANÉS (Madrid). SPAIN.
Phone: 34-91-61 99363 FAX: 34-91-61 98647
E-mail: edibon@edibon.com WEB site: www.edibon.com

Issue: ED01/10
Date: October/2010

REPRESENTATIVE: